

Research/Studio/Community/Laboratory

MARY HARDIN

The University of Arizona

This collaborative practice seeks a relationship between the specific topics of faculty research interests, the more general format of projects given in a design studio, and the needs of the surrounding community. A series of collaborations, described here illustrates the cycle of research, design/build, and subsequent research that fuels the professional practice.

An initial collaboration began when the University's Athletics and Recreation Department contacted the College of Architecture in 1997 with a request for assistance with the design of a new classroom facility. The College of Architecture countered with an offer of a design/build project, and a partnership of two years duration was formed. Students and faculty spent four semesters designing, drawing, and constructing the rammed earth classroom building.

Significantly, the collaboration created the need for research into methods of building with rammed earth. The Design/Build studio was functioning, in essence, as a building contractor with very little budget for equipment and overhead. The need to accomplish rammed earth without investing in the expensive commercial formwork used in contemporary projects led to a research goal that would eventually affect the community beyond the campus itself.

As the professors and the shop master in the College of Architecture worked to develop a forming system that would allow their students to accomplish the classroom building, the universality of the need became apparent. The problem of developing a low cost forming system for the Design/Build studio was the same as the challenge of bringing rammed earth into the affordable housing arena. Several rounds of formwork design and test walls prefaced the Design/Build studio.

Even as students shaped the classroom facility, the faculty began to realize the implications of the new forming system in the impoverished communities of the region. One Design/Build professor wrote a grant proposal for an educational partnership between the College of Architecture and a Native American community that was in dire need of additional housing. The Gila River Indian community had rejected government built housing that bore no affinity for their traditional building methods, and the tribal Housing Committee was enthused



Rammed earth walls under construction for classroom facility.



Completed wall showing chamfers and reveals.



Setting formwork for Gila River residence.

about a partnership that would train members of the Gila tribe to build rammed earth houses with a low cost system of formwork and indigenous building materials. When the grant was funded, a new collaboration was formed. One semester later, the Design/Build studio constructed the rammed earth residence in partnership with three to six members of the Gila River community each day.

The empirical testing done by the Design/Build studio for each rammed earth project led the professor to seek interdisciplinary assistance, in order to verify in a laboratory hunches that were developed in the field. A new collaboration has formed between the professor of Architecture (Mary Hardin), a professor of Civil Engineering (Scott Merry), and Habitat for Humanity. The two professors are working together (with a third crop of Design/Build students) to engineer a consistent earth and cement mix with consistent water content and compaction. This involves creating tests and testing equipment in the University's Soils Lab to establish the ideal soil conditions, and then experimenting to find ways of controlling field practices of rammed earth construction to achieve the same results. The Design/Build studio will employ these methods in the construction of a residence for habitat for Humanity during the spring semester of 2001. The house has already moved through the design and drawing stages.

As series of collaborations, this architectural practice has provided the basis for classroom learning, experiential learning, service learning, and rigorous research for all parties involved.



Stripping forms from Gila house.



Massive walls of Gila residence take shape.



Forming for bond beam of Gila house.

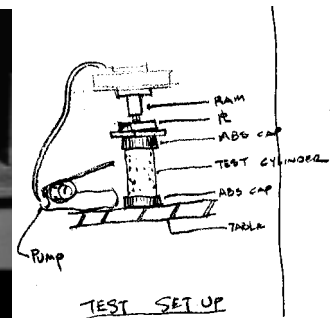
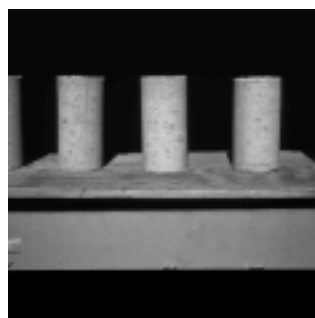

Tests begin for Habitat house.